

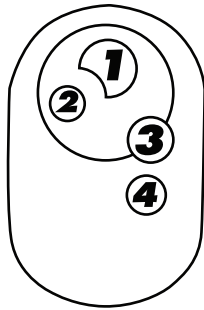

**USER GUIDE AND INSTALLATION MANUAL
KEYLESS ENTRY SYSTEM**

AUTKL400 4 channel system



Remote Transmitter
(illustration may vary from actual remote)

Button	Function	Condition
1	Enable starter/ignition kill and lock door LOCK	Starter/ignition kill disabled
2	Disable starter/ignition kill and unlock door UNLOCK	Starter/ignition kill enabled
3	3rd channel output	Anytime
4	4th channel output	Anytime

USER GUIDE

CODE LEARNING

- Turn key to ON position (yellow ACC wire must be hooked up), press valet button for 3 seconds. The parking lights will flash once to indicate code learning mode. Press any button in order to learn the desired remote. The parking lights will flash once for confirmation, after each remote transmitter is learned. Up to 4 remote transmitters can be learned at this time.
- Turn key to OFF position or wait for 5 seconds and system will exit code learning.

REMOTE DOOR LOCKING

- Press button 1. The parking lights will flash once. The starter/ignition kill circuit will be enabled and the lock output will pulse for 1 second or until button 1 is released.
- LED will begin flashing slowly.

REMOTE DOOR UNLOCKING

- Press button 2. The parking lights will flash twice. The starter/ignition kill circuit will be disabled and the unlock output will pulse for 1 second or until button 2 is released.
- LED will be off.

CH3 OUTPUT

Press button 3 to output channel 1 continuously until button 3 is released.

CH4 OUTPUT

Press button 4 to output channel 2 continuously until button 4 is released.

WIRING DIAGRAM

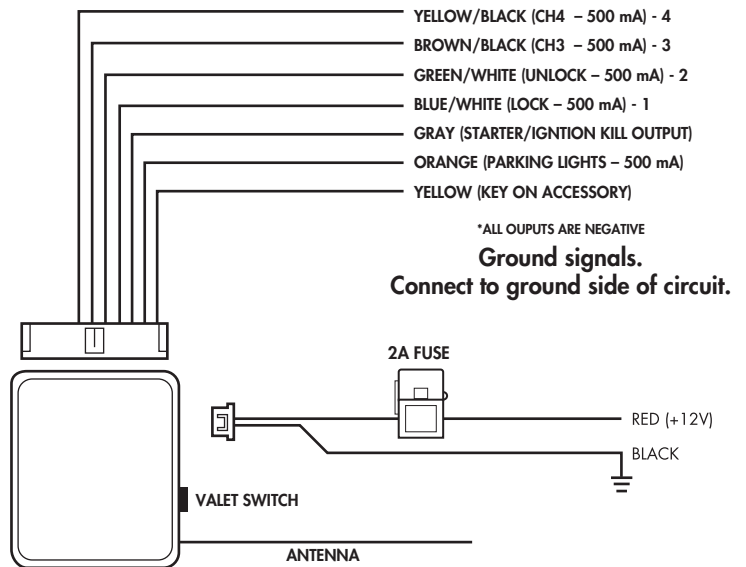

STARTER/IGNITION KILL

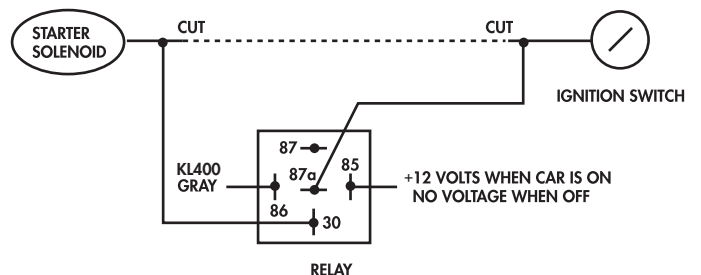

WIRING DIAGRAMS

PARKING LIGHTS

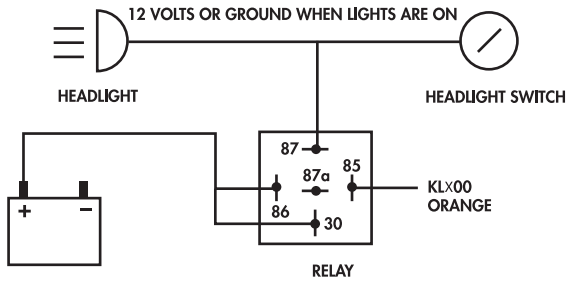

TRUNK/SHAVED DOOR HANDLE TRIGGER

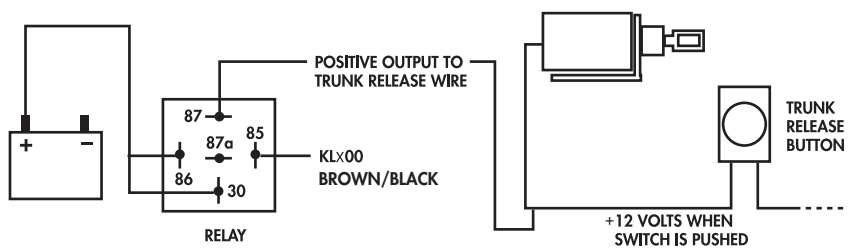

DOOR LOCK WIRING DIAGRAMS

NEGATIVE SYSTEM

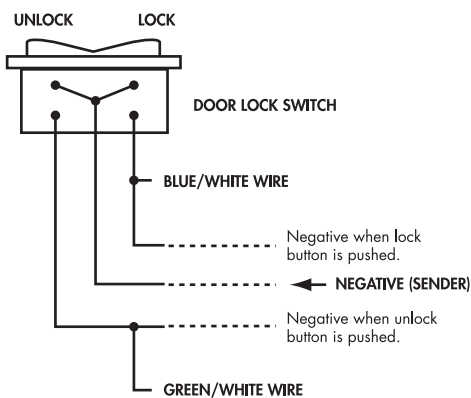

Negative and Positive triggers are the two main types of door locking systems. To determine the type of system you have simply connect the testlight wire to a ground (-), then probe all wires from your door lock switch to determine the Lock and Unlock wire.

1. If you come to a wire that LOCKS your doors when probed (-), then you have found the lock wire. Connect the BLUE/WHITE wire from the keyless entry unit to this wire.
2. If you come to a wire that UNLOCKS your doors when probed (-), then you have found the unlock wire. Connect the GREEN/WHITE wire from the keyless entry unit to this wire.

POSITIVE SYSTEM

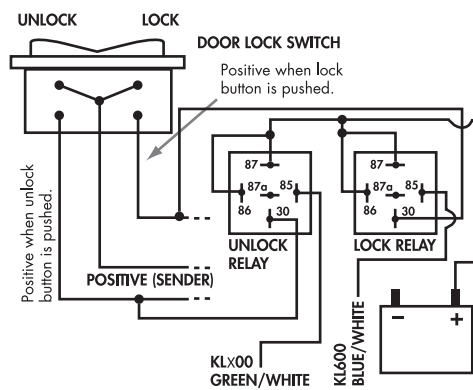

If you can not find a wire that will lock or unlock your doors with a negative trigger then you have a positive trigger system. Connect the test light wire to 12 volts (+). Now probe all wires to determine the Lock and Unlock wire.

1. If you come to a wire that LOCKS your doors when probed (+), then you have found the lock wire. Using the wire diagram connect this wire to terminal 30 of the lock relay.
2. If you come to a wire that UNLOCKS your doors when probed (+), then you have found the unlock wire. Using the wire diagram connect this wire to terminal 30 of the unlock relay.
3. Connect the GREEN/WHITE wire from the keyless entry unit to terminal 85 of the unlock relay.
4. Connect the BLUE/WHITE wire from the keyless entry unit to terminal 85 of the lock relay.
5. Connect terminal 86 and 87 of both relays to a constant 12 volt power source (battery).

REVERSE POLARITY SYSTEM

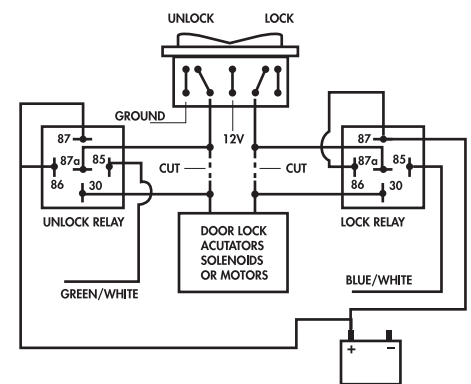

If you can not find a wire that will lock or unlock your doors when given a positive, or negative trigger then you have a reverse polarity System. Your switch should have at least 5 wires. 2 wires will be grounded, 1 wire will have power when you push the window switch "UP", 1 wire will have power when you push the window switch "down", and 1 wire will have a constant 12 volts.

1. Cut the factory unlock wire.
2. Connect the factory unlock wire that comes from the switch to terminal 87a, of the unlock relay.
3. Connect the other side of the factory unlock wire to terminal 30, of the unlock relay.
4. Cut the factory lock wire.
5. Connect the factory lock wire that comes from the switch to terminal 87a, of the lock relay.
6. Connect the other side of the factory lock wire to terminal 30 of the lock relay.
7. Connect constant 12v power source (battery) to terminals 86 and 87 on both unlock and lock relays.
8. Connect the BLUE/WHITE wire to terminal 85 of the lock relay.
9. Connect the GREEN/WHITE wire to terminal 85 of the unlock relay.