

HZ-4300-KIT Installation Instructions (cont'd)

Be sure to use belt # **K060675** on your serpentine pulley system. After adjusting the belt tensioning rod, be sure to tighten all the bracket bolts on HZ-4300 alternator bracket and HZ-4306 power steering bracket.

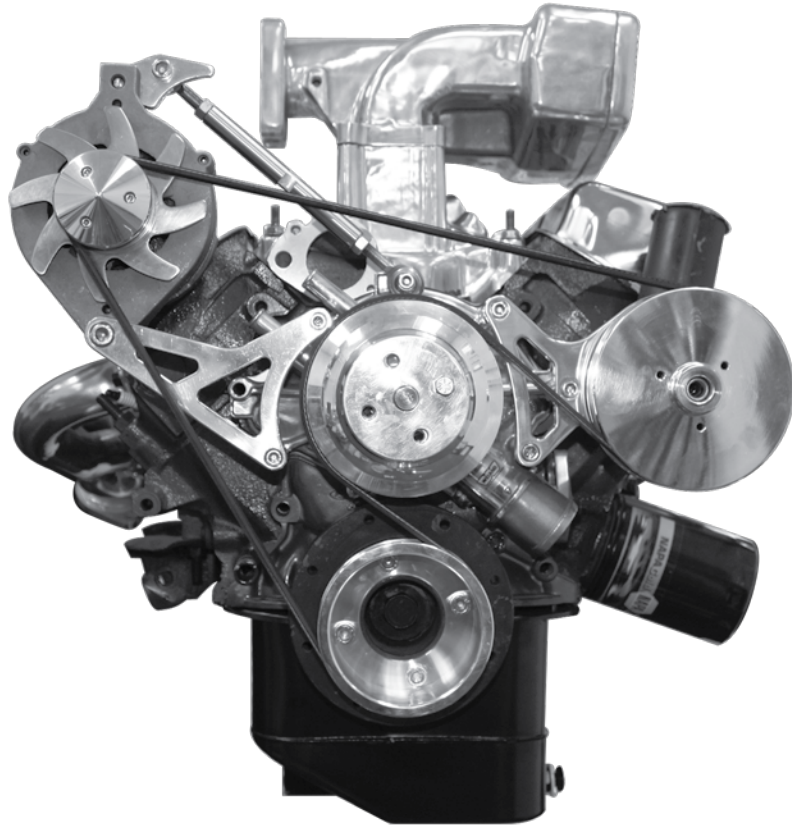

CFR PERFORMANCE



HZ-4300, HZ-4306, HZ-4300-KIT

Ford Mustang 5.0L

Alternator Bracket Set (HZ-4300)

Power Steering Bracket Set (HZ-4306)

Serpentine Pulley & Bracket Kit (HZ-4300-KIT)

Installation Guide

CFR PERFORMANCE

(800) 838-8024

www.cfrperformance.com

(800) 838-8024 **www.cfrperformance.com**

1260 East Locust Street, Suite #301 Ontario, CA 91761

HZ-4300 Alternator Bracket Set



HZ-4300 Installation Instructions

1. Attach alternator bracket to water pump using 6-1/4" bolt and 2-1/4" spacer through the lower bracket hole.
2. Insert and tighten 4-1/4" bolt and 1-1/4" spacer through the upper bracket hole. (NOTE: Spacers go behind the alternator bracket.)

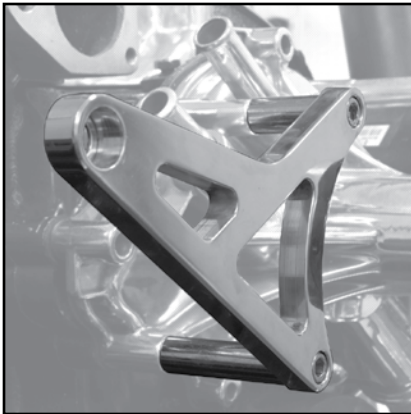

3. Mount the alternator behind the bracket using 6-7/8" bolt and 2-1/2" spacer and tighten to engine head.
4. Attach the supporting alternator bracket to the top of the alternator using a 1-5/8" bolt.

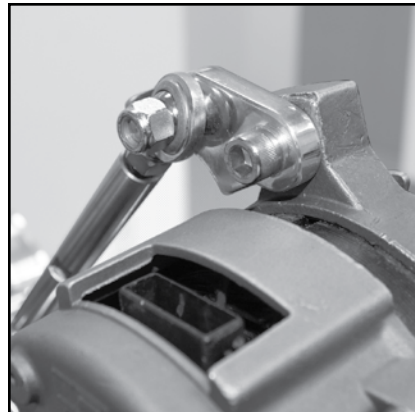
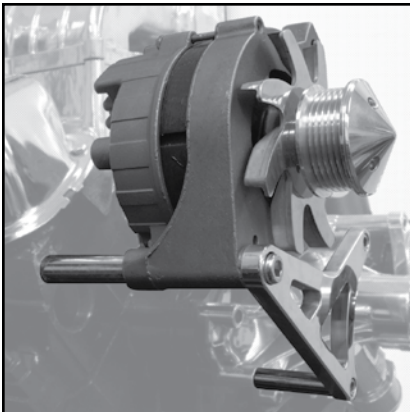

5. Attach belt tensioning rod to the water pump using a 3" bolt. Then attach the other end of the belt tensioning rod to the supporting alternator bracket (backside) using a 1-5/8" bolt and washer. (NOTE: Place washer between tensioning rod and nut.)

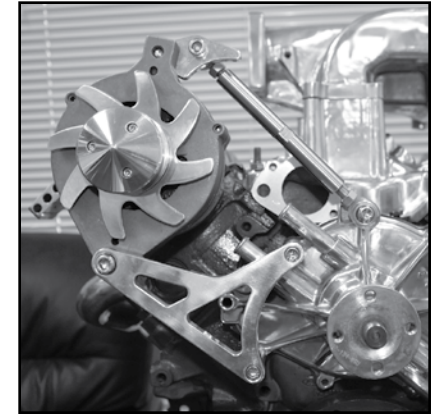
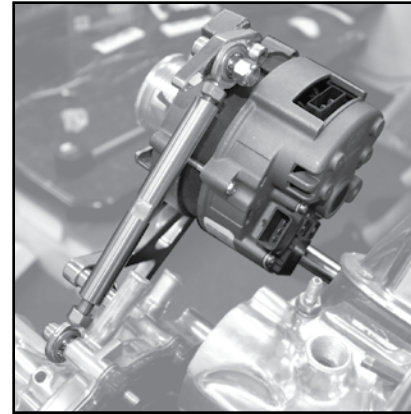

HZ-4306 Installation Instructions

1. Attach the power steering bracket to the block using two 6" bolts with 1-3/4" spacers. (NOTE: The power steering bracket mounts to the block through the water pump. The upper left hole and lower right holes use the 6" bolts with 1-3/4" spacers.)
2. Insert and tighten the 4-1/4" bolt with the 1/2" spacer through the remaining lower left bracket hole.
3. Attach the power steering pump to the bracket using three 1-1/8" bolts.

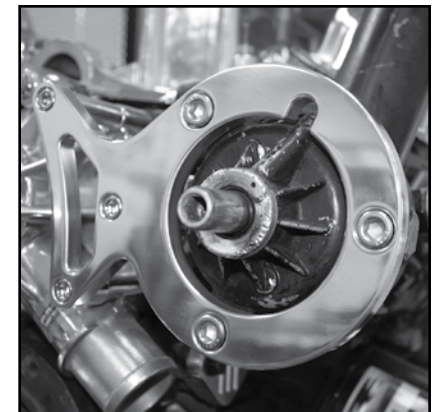
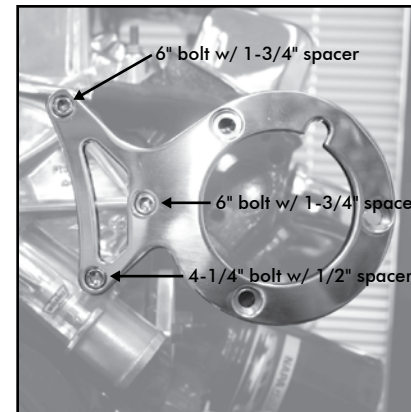

HZ-4300-KIT Installation Instructions

After installing the two bracket sets specified above, you can now mount the pulleys to the engine. Be sure to attach pulleys correctly and torque the bolts appropriately (see next page).

NOTE: PULLEY SET MUST BE USED WITH A REVERSE ROTATION WATER PUMP.